

# MEDIUM-INTENSITY Type A+B/C

ICAO MI Type A 20 000cd  
 ICAO MI Type B/C 2 000cd  
 FAA L-865+L-864, F-866+L-885

**OBELUX**  
 AVIATION LIGHTS

Obelux Oy, Kutomotie 6 B, 00380 Helsinki FINLAND | The information in this document is subject to change without notice. © Obelux Oy 2018

WWW.OBELUX.COM

## Optical characteristics

- ▶ 20 000 / 2 000cd (effective)
- ▶ Colour aviation WHITE and RED
- ▶ NVG compliant infrared (850nm) as an option
- ▶ Horizontal beam 360°
- ▶ Vertical beam 3°
- ▶ Maximum intensity at -1° is less than 11 250cd (WHITE), 1125cd (RED)
- ▶ Maximum intensity at -10° is less than 750cd (WHITE), 75cd (RED)

## Specifications met

ICAO International Standards and Recommended Practices:  
 Aerodromes Annex 14 Volume 1,  
 7th Edition, July 2016, Chapter 6:  
 Medium-intensity Type A  
 Medium-intensity Type B/C. Fulfills  
 the Recommendations Section in  
 Table 6-3.

FAA Advisory Circular  
 AC 150/5345-43G:  
 FAA L-865+L-864, F-866+L-885

nach Nr. 28 der Allgemeinen  
 Verwaltungsvorschrift zur  
 Kennzeichnung von  
 Luftfahrthindernissen (AVV  
 Kennzeichnung), Germany

Feux de balisage d'obstacle, DGAC,  
 STAC, France

Transport Canada, CAR 621,  
 CL-865+CL-864, CL-866+CL-885

Agencia Estatal de Seguridad Aérea  
 (AESA), Mexico.

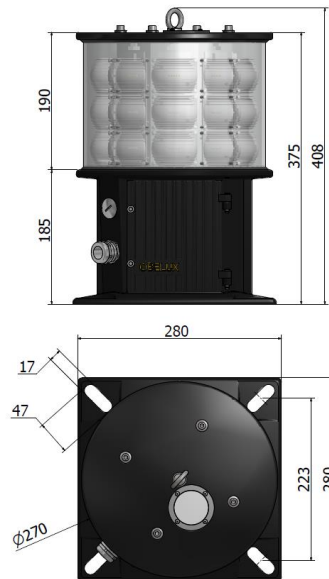

## Medium-Intensity White and Red Dual 20 000cd LED Aviation Obstruction Lights

Obelux medium-intensity stand-alone 20 000cd White and Red model is used for marking tall structures, such as wind turbines, transmission masts, chimneys, broadcast masts, etc. The product offers unique features such as incorporated fault monitoring, photocell, GPS synchronization, and it supports both stand-alone and Modbus operation as a part of Obelux aviation light system network.

### Key Features

- ▶ Based on LED technology
- ▶ 20 000 cd (effective) WHITE flashing and RED fixed or flashing
- ▶ Supports both stand-alone and Modbus operations
- ▶ Suitable for Offshore environment
- ▶ Incorporated GPS synchronisation
- ▶ Adjustable luminous output levels 10%, 30%, and 100%
- ▶ Incorporated photocell and fault monitoring
- ▶ Hot start feature for radar controlled systems
- ▶ Design lifetime more than 20 years
- ▶ 5-year warranty- the longest in the industry

# MEDIUM-INTENSITY Type A+B/C

ICAO MI Type A 20 000cd  
 ICAO MI Type B/C 2 000cd  
 FAA L-865+L-864, F-866+L-885

**OBELUX**  
 AVIATION LIGHTS

Obelux Oy, Kutomotie 6 B, 00380 Helsinki FINLAND | The information in this document is subject to change without notice. © Obelux Oy 2018

WWW.OBELUX.COM

## Electrical Characteristics

- ▶ Operating voltage (ACW): 90-265V<sub>AC</sub>, 50Hz / 60Hz ± 6%
- ▶ Operating voltage (DC): 20-60V<sub>DC</sub>
- ▶ Flash rates: 20/30/40/60 fpm
- ▶ Meets standards
  - EMC (Emissions): EN 61000-6-4
  - EMC (Immunity): EN 61000-6-2
- ▶ Power consumption for ACW versions
  - 19W @ Day (WHITE, 40 fpm)
  - 4W @ Night (WHITE, 40 fpm)
  - 5,5W @ Night (WHITE+IR, 40 fpm)
  - 17W @ Night (RED, 40 fpm)
  - 20W @ Night (RED+IR, 40 fpm)
  - 25W @ Night (RED, fixed)
  - 30W @ Night (RED+IR, fixed)

(Flash pulse length in day and twilight mode is 100ms. Flash pulse length for the RED light is 50% of the selected flash rate.)

- ▶ Power consumption for power-save use (ACW versions)
  - 8W @ Night (RED, 40fpm)
  - 11W @ Night (RED+IR, 40fpm)

(Flash pulse length for the RED light is approx. 200ms)

- ▶ Recommended cables (Outdoor) for ACW versions:
  - Power (L-N-PE): 3x1,5mm<sup>2</sup> or 3x2,5mm<sup>2</sup>
  - Data: CAT 6
  - Alarm: CAT 6, 3x1,5mm<sup>2</sup> or 3x2,5mm<sup>2</sup>
  - Power + Alarm: 6x1,5mm<sup>2</sup> or 6x2,5mm<sup>2</sup>
- ▶ Terminals can be used to distribute power and data to another light head (6 core cable must be used).

## Mechanical Characteristics

- ▶ Painted marine grade aluminium body (C5MHigh)
- ▶ Glass cover
- ▶ Degree of protection IP66
- ▶ Operating temperature range -40...+55 °C
- ▶ Mounting 240x240mm, φ17mm
- ▶ Height 408 mm, diameter 270 mm
- ▶ Weight 14 kg

## Additional Factory-Installed Options

- ▶ Cold-climate version (CCV)
- ▶ NVG compliant infrared (IR)

Order code	Output	ICAO	Op. volt.	GPS sync h	Infrared	CCV	Photocell and Fault monitoring	Packing dimensions (mm)
MID-ACWGAM	20 000cd	Type A+B/C	90-265VAC	Yes	No	No	Yes	460x330x330, 15,5kg
MID-ACWIRGAM	20 000cd	Type A+B/C	90-265VAC	Yes	Yes	No	Yes	460x330x330, 15,5kg
MID-ACWCCVGAM	20 000cd	Type A+B/C	90-265VAC	Yes	No	Yes	Yes	460x330x330, 15,5kg
MID-ACWCCVIRGAM	20 000cd	Type A+B/C	90-265VAC	Yes	Yes	Yes	Yes	460x330x330, 15,5kg
MID-FAA-ACWGAM	20 000cd	Type A+B/C*	90-265VAC	Yes	No	No	Yes	460x330x330, 15,5kg
MID-FAA-CCVACWGAM	20 000cd	Type A+B/C*	90-265VAC	Yes	Yes	Yes	Yes	460x330x330, 15,5kg
MID-DCGAM	20 000cd	Type A+B/C	20-60VDC	Yes	No	No	Yes	460x330x330, 15,5kg
MID-DCIRGAM	20 000cd	Type A+B/C	20-60VDC	Yes	Yes	No	Yes	460x330x330, 15,5kg
MID-DCCCVGAM	20 000cd	Type A+B/C	20-60VDC	Yes	No	Yes	Yes	460x330x330, 15,5kg
MID-DCCCVIRGAM	20 000cd	Type A+B/C	20-60VDC	Yes	Yes	Yes	Yes	460x330x330, 15,5kg

\*provides correct dip switch settings also for FAA and Mexico market in a stand-alone operation, further information is presented in user manual.

# MEDIUM-INTENSITY Type A+B/C

ICAO MI Type A 20 000cd  
 ICAO MI Type B/C 2 000cd  
 FAA L-865+L-864, F-866+L-885

**OBELUX**  
 AVIATION LIGHTS

Obelux Oy, Kutomotie 6 B, 00380 Helsinki FINLAND | The information in this document is subject to change without notice. © Obelux Oy 2018

WWW.OBELUX.COM

## 20 000 cd / 2 000 cd WHITE only products

Order code	Output	ICAO	Op. volt.	GPS sync h	Infrared	CCV	Photocell and Fault monitoring	Packing dimensions (mm)
<b>MI-ACWGAM-A</b>	20 000cd	Type A	90-265VAC	Yes	No	No	Yes	460x330x330, 15,5kg
<b>MI-ACWIRGAM-A</b>	20 000cd	Type A	90-265VAC	Yes	Yes	No	Yes	460x330x330, 15,5kg
<b>MI-ACWCCVGAM-A</b>	20 000cd	Type A	90-265VAC	Yes	No	Yes	Yes	460x330x330, 15,5kg
<b>MI-ACWCCVIRGAM-A</b>	20 000cd	Type A	90-265VAC	Yes	Yes	Yes	Yes	460x330x330, 15,5kg
<b>MI-FAA-ACWGAM-A</b>	20 000cd	Type A	90-265VAC	Yes	No	No	Yes	460x330x330, 15,5kg
<b>MI-FAA-CCVACWGAM-A</b>	20 000cd	Type A	90-265VAC	Yes	Yes	Yes	Yes	460x330x330, 15,5kg
<b>MI-DCGAM-A</b>	20 000cd	Type A	20-60VDC	Yes	No	No	Yes	460x330x330, 15,5kg
<b>MI-DCIRGAM-A</b>	20 000cd	Type A	20-60VDC	Yes	Yes	No	Yes	460x330x330, 15,5kg
<b>MI-DCCCVGAM-A</b>	20 000cd	Type A	20-60VDC	Yes	No	Yes	Yes	460x330x330, 15,5kg
<b>MI-DCCCVIRGAM-A</b>	20 000cd	Type A	20-60VDC	Yes	Yes	Yes	Yes	460x330x330, 15,5kg

### Available mounting set as an option

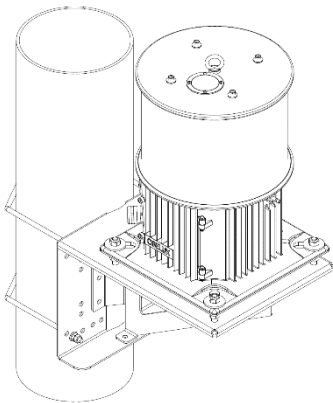

#### Obelux MS-MIV1001

Mounting set for wall mounting and for 60-200mm tubes.

This mounting set includes:

- ▶ 2 pcs U-bolt 60-100
- ▶ 2 pcs U-bolt 100-200
- ▶ 8 pcs M8 hex nut ISO 4161
- ▶ 8 pcs M8 hex nut ISO 4032
- ▶ 8 pcs M10 hex nut ISO 4032
- ▶ 4 pcs M10 hex nut ISO 4161
- ▶ 4 pcs washer DIN 9021 - 13

All parts are AISI316 acid-proof stainless steel.

More detailed mechanical data: see MS-MIV1001 datasheet

▶ Order Code MS-MIV1001